

TECHNICAL DATA SHEET

SUCTION NOZZLE

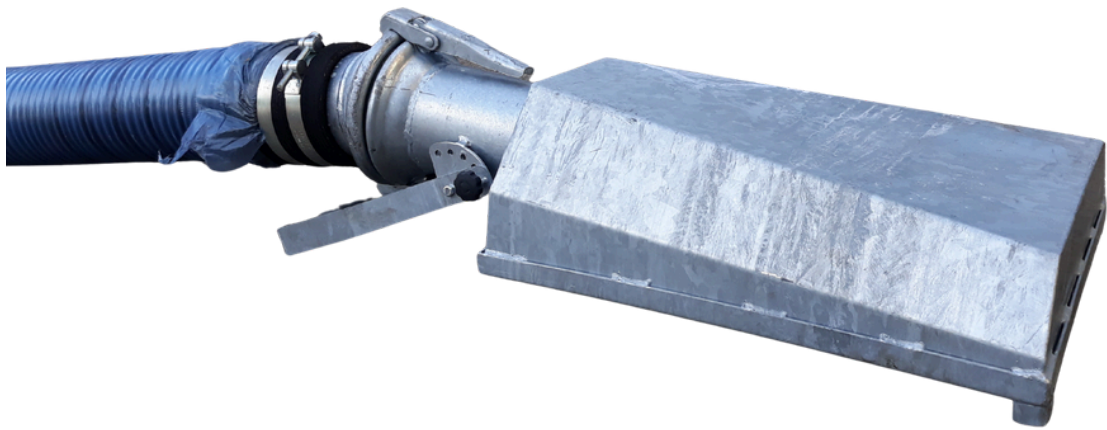



Bottom valve with suction nozzle

The “suction” bottom valve in **hot-dip galvanized steel** for **liquid withdrawal**, installed on the hydraulic system’s suction line, **to retain larger impurities**. A special version with an adjustable system for complete liquid drainage, inlet with a **grate to protect against solid objects** that could damage the suction pipe and pump. Available in various sizes with spherical fittings of different diameters.

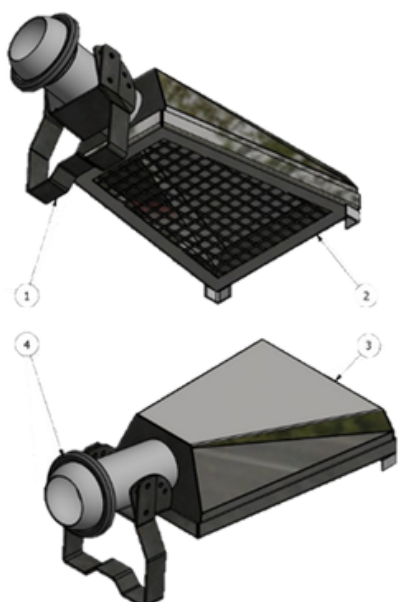

Adjustment system

to ensure complete liquid drainage

Protective grate

against the entry of solid objects

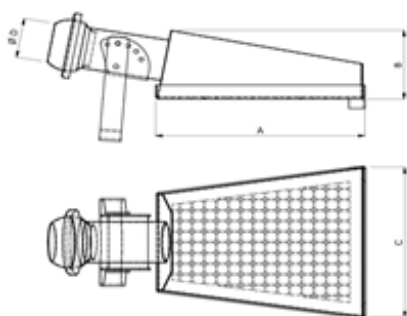

ØD	A	B	C
80	395	150	325
100	395	150	325
120	380	220	550
150	308	220	550
200	400	320	550

