

# SCHEDA TECNICA

BASAMENTO TRAINABILE PORTA

FILTRI MODULABILE

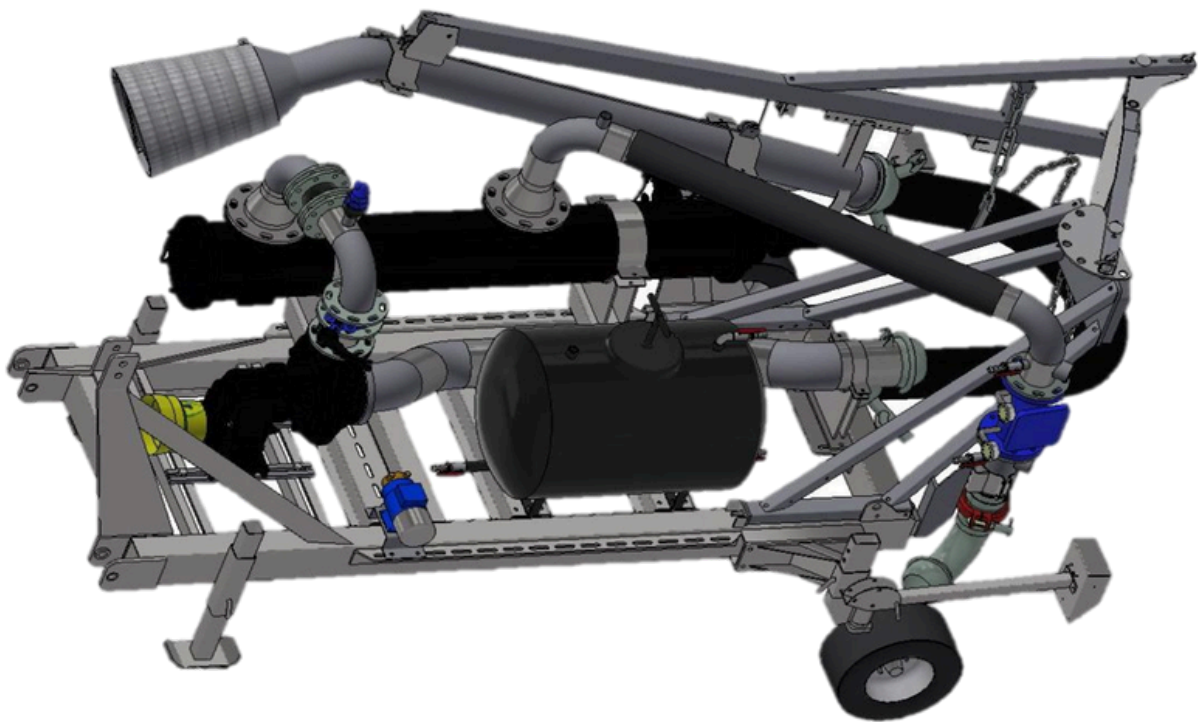



**Supporto d'aspirazione brevettato, richiudibile**

**Serbatoio da 200 Lt per concime**

**Filtro automatico**

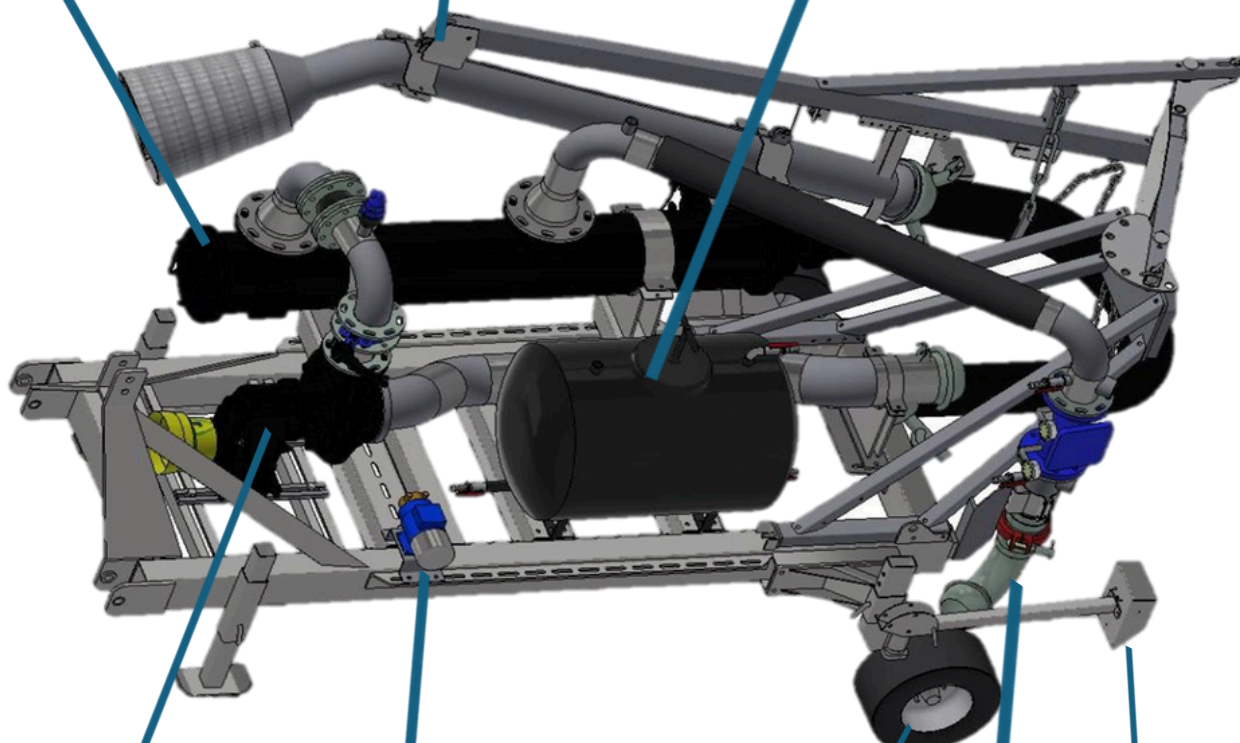

**Pompa per bassa pressione**

**Elettropompa per riempimento pescante**

**Ruote pivottanti**

**Luci stradali**

**Collo di cigno orientabile**



## Girante

	<i>H (m)</i>	61,3	60	57,3	54	47,5
<b>I</b>	<i>HP</i>	42	47	52	55,5	58
	<b>H (m)</b>	<b>75,3</b>	<b>74</b>	<b>71,7</b>	<b>68,6</b>	<b>63,5</b>
<b>G</b>	<i>HP</i>	52,8	59,8	66	70,8	74,2
	<b>H (m)</b>	<b>88</b>	<b>87,2</b>	<b>85,8</b>	<b>83</b>	<b>77,5</b>
<b>E</b>	<i>HP</i>	66,5	73	80	66	91,5

## Pompa

Potenza trattore minima	Min-1 P.F per rapporto	Modello pompa	Aspirazione per mandata
70	505X5,93	T4-125	125X100
90	550X5,47	T4-125	125X100
110	880X3,41	T4-125	125X100

## Portata

<b>l/min</b>	2000	2500	3000	3500	4000	4500	5000	5500
<b>m3/h</b>	120	150	180	210	240	270	300	330
<b>l/s</b>	33,3	41,6	50	58,3	66,6	75	83,3	91,5

## FILTOMAT MOD. M-106XLP

Attacchi (mm)	Max. portata m3/h	Superficie filtrante cm2	KG	Portata minima di lavaggio m3/h	Acqua scaricata per ciclo (a 2 bar)
150/6"	150	6800	120	30	150