

# TECHNICAL DATA SHEET

TOWABLE BASE FOR DOORS

MODULAR FILTERS

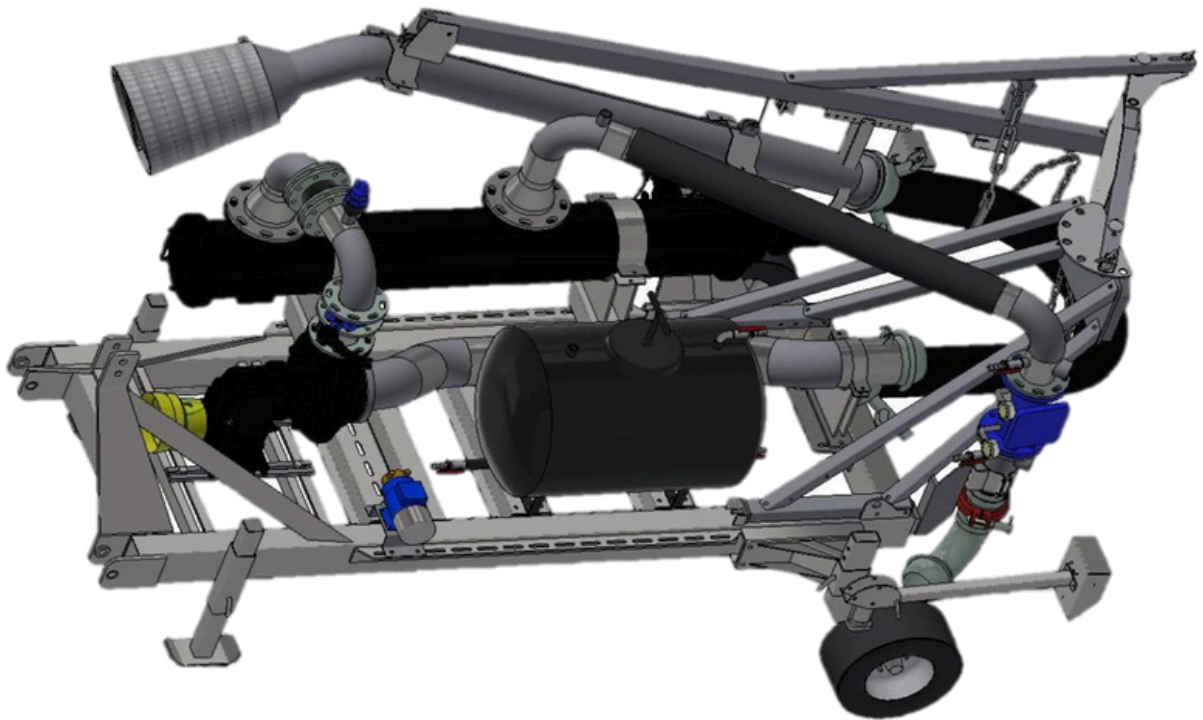



Patented, foldable suction support

200-litre tank for fertiliser

Automatic filter

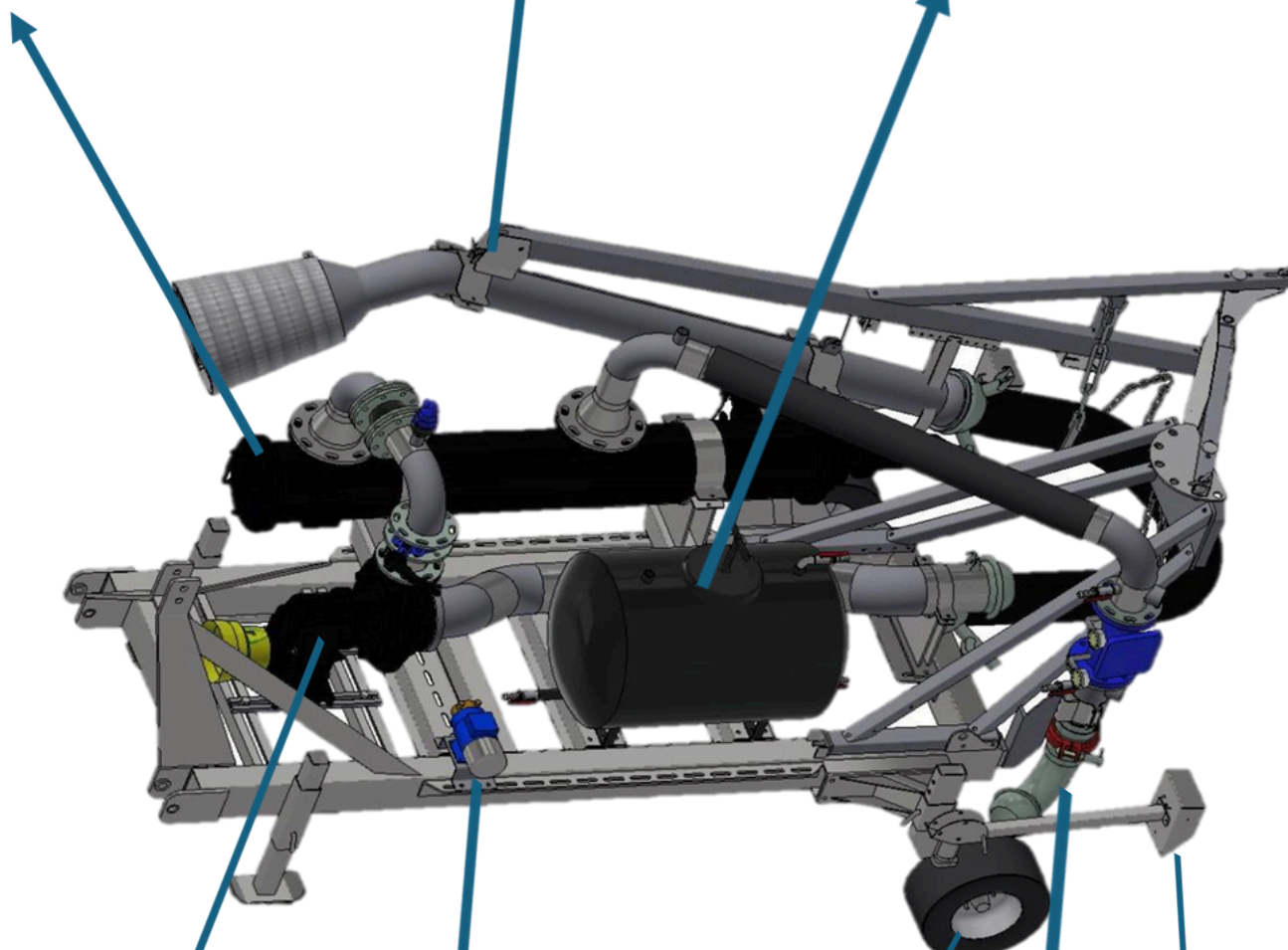

Low pressure pump

Electric pump for suction filling

Pivoting wheel

Street lights

Adjustable swan neck



## Impeller

	<i>H (m)</i>	61,3	60	57,3	54	47,5
<b>I</b>	<i>HP</i>	42	47	52	55,5	58
	<b>H (m)</b>	<b>75,3</b>	<b>74</b>	<b>71,7</b>	<b>68,6</b>	<b>63,5</b>
<b>G</b>	<i>HP</i>	52,8	59,8	66	70,8	74,2
	<b>H (m)</b>	<b>88</b>	<b>87,2</b>	<b>85,8</b>	<b>83</b>	<b>77,5</b>
<b>E</b>	<i>HP</i>	66,5	73	80	66	91,5

## Pump

Minimum tractor power	Min-1 P.F per ratio	Pump model	Suction per delivery
70	505X5,93	T4-125	125X100
90	550X5,47	T4-125	125X100
110	880X3,41	T4-125	125X100

## Flow rate

<b>l/min</b>	2000	2500	3000	3500	4000	4500	5000	5500
<b>m3/h</b>	120	150	180	210	240	270	300	330
<b>l/s</b>	33,3	41,6	50	58,3	66,6	75	83,3	91,5

## FILTOMAT MOD. M-106XLP

Attacks (mm)	Max. flow rate m <sup>3</sup> /h	Filter surface area cm <sup>2</sup>	KG	Minimum washing flow rate m <sup>3</sup> /h	Water discharged per cycle (at 2 bar)
150/6"	150	6800	120	30	150